

**DATA SHEET**

**WINTERGREEN ODORIZER**

PART NO : IH324

OLD DWG. NO:DP-5.8/08-116

DATE: MAR.2008

REVISION : 00

SCALE : N.T.S

SHEET: 1 OF 1

APPD. BY : D.B

NEW DWG. NO:DP-5.8/MT-268

DATE: JAN.2013

INTRODUCTION :-

WINTERGREEN ODORIZER IS TO BE INSTALLED IN THE DISTRIBUTION PIPE AFTER DIRECTIONAL VALVE TO PROVIDE ALERT SIGN FOR EVACUATION IN THE PROTECTED AREA.

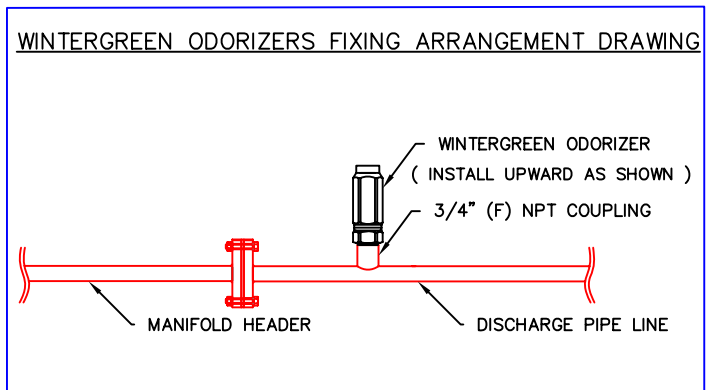
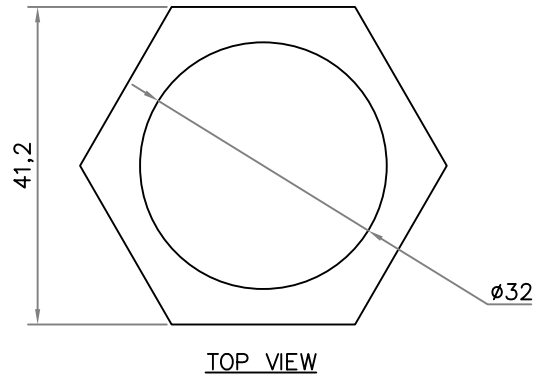
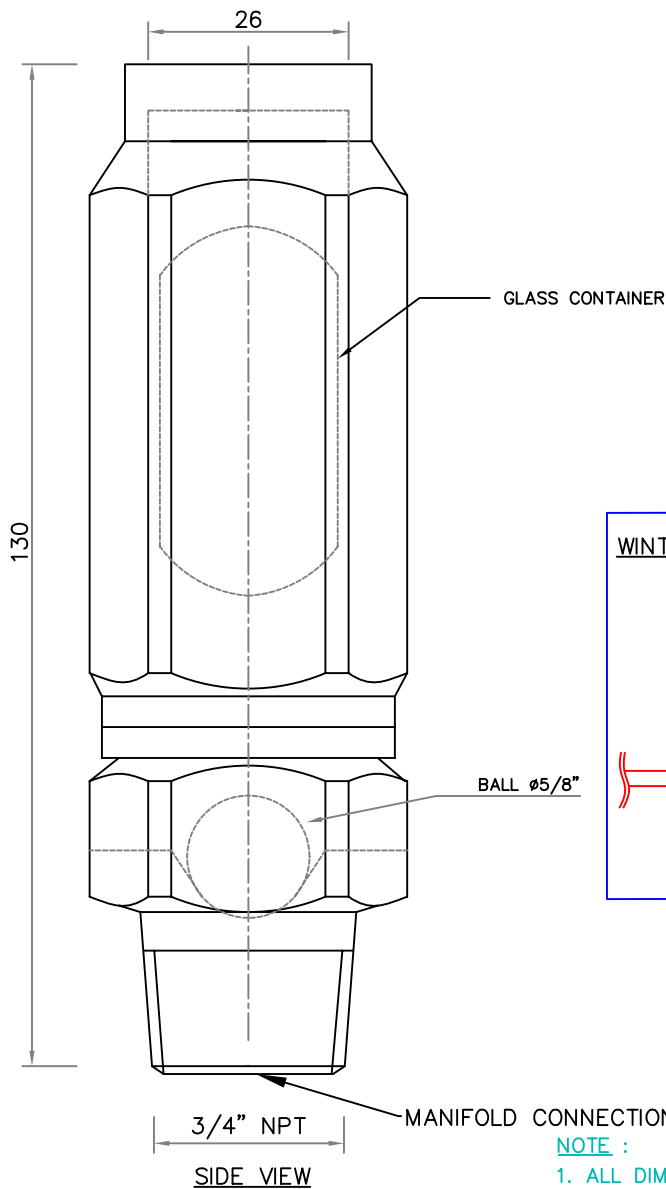

NOTE :

1. ALL DIMENSIONS ARE IN "mm" UNLESS OTHERWISE SPECIFIED.
2. TOLERANCE ON DIMENSION ± 3 MM, UNLESS OTHERWISE SPECIFIED.

TECHNICAL SPECIFICATION

01. MANUFACTURER	AGNI CONTROLS - CHENNAI	06. ODORIZER	WINTERGREEN
02. MATERIAL OF CONSTRUCTION	BRASS	07. QUANTITY	15 ML
03. INNER BALL	SS304		
04. TEST PRESSURE	75 BAR HYDRAULIC		
05. WORKING PRESSURE	50 BAR.		

IMPORTANT:

AGNI CONTROLS RESERVES THE RIGHT TO CHANGE OR MODIFY WITHOUT PREVIOUS NOTICE ANY DATA OR SPECIFICATION DUE TO CHANGES OR MODIFICATION IN ORDER TO IMPROVE THE PRODUCTS / SYSTEM PRESENTED.



**AGNI CONTROLS  
CHENNAI**

NO.1, 6TH STREET, Dr.SUBBARAYAN NAGAR,  
KODAMBAKKAM, CHENNAI-600 024, INDIA.

PHONE : +91 44 2481 2420, FAX : +91 44 2481 2475,

E-MAIL : engineering@agnicontrols.com WEBSITE : www.balafire.com

**ISO 9001 - 2008  
CERTIFIED BY  
BUREAU VERITAS**