

**DATA SHEET**

**CO<sub>2</sub> EXTINGUISHING CYLINDER ASSEMBLY KIT  
FULLY INTEGRATED AND TESTED**

PART NO :  
BIH001-48/68-TXFP

DP-5.8/10-266

DATE: MAR 2011

REVISION : 00

SCALE : N.T.S

SHEET: 1 OF 1

APPD. BY : DB

MODEL NO :

INTRODUCTION :-

TYPICAL CO<sub>2</sub> EXTINGUISHING CYLINDER ASSEMBLY KIT FOR FIXED INSTALLATION CO<sub>2</sub> FIRE EXTINGUISHING SYSTEM SUITABLE FOR 68 LITRES WATER CAPACITY CYLINDER.

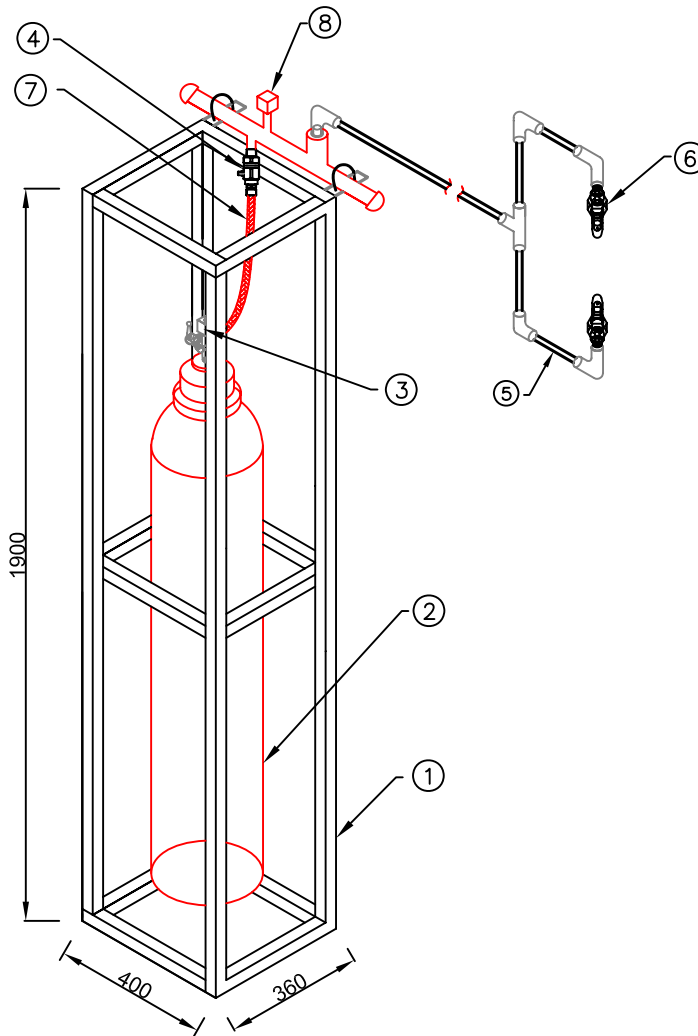

NOTE:

1. ALL DIMENSIONS ARE IN "mm" UNLESS OTHERWISE SPECIFIED.
2. TOLERANCE ON DIMENSION  $\pm 3$  mm, UNLESS OTHERWISE SPECIFIED.

NO.	PART NO	NAME OF THE PARTS	NO.	PART NO	NAME OF THE PARTS
01.	IH396	FRAME ASSEMBLY	05.	IH217 SS- $\phi$ 12mm	6 mtrs. SS TUBE
02.	B048-68	68 LITRES WATER CAPACITY CO <sub>2</sub> CYLINDER	06.	IH011/1	CO <sub>2</sub> NOZZLE
03.	B001/DIN	CO <sub>2</sub> MASTER VALVE DIN477 THREADING STANDARD	07.	B020	HIGH PRESSURE DISCHARGE HOSE-400mm
04.	IH018	MASTER NON-RETURN VALVE	08.	B143	PRESSURE SWITCH

IMPORTANT:

AGNI CONTROLS RESERVES THE RIGHT TO CHANGE OR MODIFY WITHOUT PREVIOUS NOTICE ANY DATA OR SPECIFICATION DUE TO CHANGES OR MODIFICATION IN ORDER TO IMPROVE THE PRODUCTS / SYSTEM PRESENTED.



AGNI CONTROLS  
CHENNAI

NO.1, 6TH STREET, Dr.SUBBARAYAN NAGAR,  
KODAMBAKKAM, CHENNAI-600 024, INDIA.

PHONE : +91 44 2481 2420, FAX : +91 44 2481 2475,

E-MAIL : engineering@agnicontrols.com WEBSITE : www.balafire.com

ISO 9001 - 2008  
CERTIFIED BY  
BUREAU VERITAS